

Article number: 20652018

Description: E+G Centring bore clamp GN 411.2-18.5-K

Measures

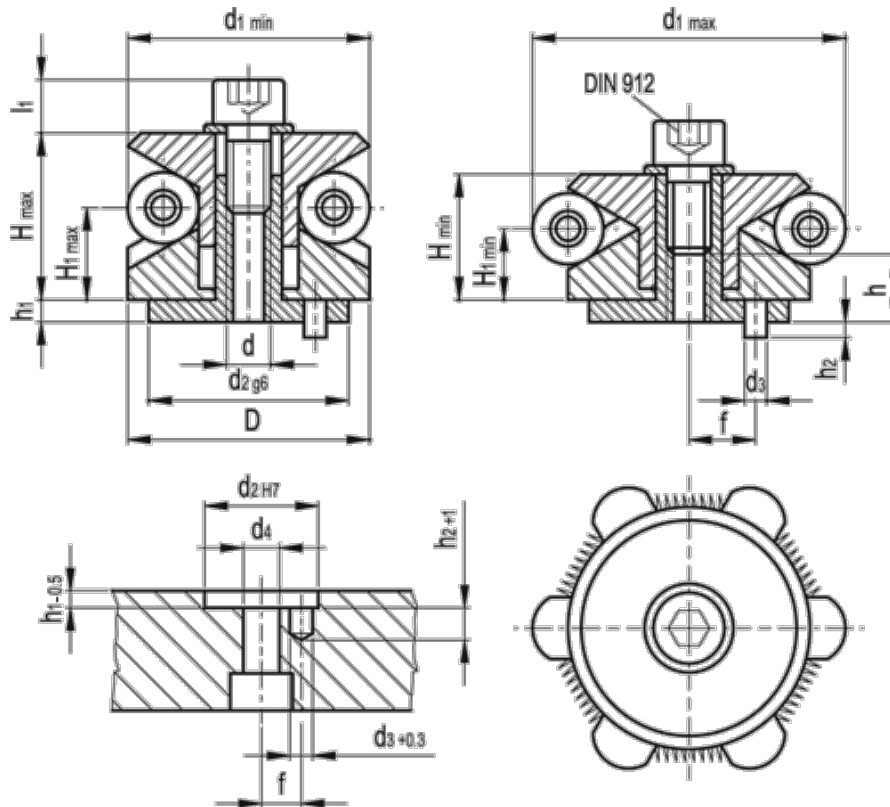

Clamping force (kN) = 4.50	d4 = 5.3	H min = 12.3
Clamping points = 3	f +/-0.1 = 5.5	l1 = 7.0
D = 18.5	h1 = 3.0	Weight (g) = 39
d = M5	H1 max = 9.6	
d1 max = 22.5	H1 min = 8.4	
d1 min = 18.5	h2 = 3.0	
d2 g6/H7 = 15	H max = 14.6	
d3 = 2.5	h min = 6	